

# THE LIGHTER NOTE



## The ultimate volume control?

AMONG THE EARLIEST designs to use light-dependent resistors (LDRs) to control volume in domestic audio and certainly the first to enjoy continued success over many years was George Stantscheff's LightSpeed Passive Attenuator. Generously and unusually, George shared and discussed his design with the DIY community (for personal use *only*) in a lengthy thread on the DIYAUDIO forum.

Constructors should read the first dozen or so pages of this to get a feel both for the unique qualities of LDR-based volume controls and for their limitations.

With the development of THE LIGHTER NOTE kit, BuildAnAmp designer Uriah Dailey takes LDR attenuators to a new level by addressing these limitations and by significantly improving on the technology's already impressive audio quality. Among the 'tricks up his sleeve' are:

- A high-quality power supply.  
A current-source supply significantly improves the sound quality of an LDR attenuator and a simple but remarkably effective one has been developed for THE LIGHTER NOTE.  
Inevitably, noise in the power supply flows through the LEDs. Though the LDRs are coupled optically rather than electrically, it can propagate into the signal and degrade the sound. The ultra-low-noise circuit used here thus pays worthwhile dividends. As a 'last line of defence', the LDRs are fully 'snubbed';
- High-value by-pass resistors.  
By design, an attenuator provides the input signal with a resistance path to ground. Coupled with the capacitance of the interconnect cables, it thus forms a low-pass filter which, by definition, attenuates high frequencies. In THE LIGHTER NOTE, high-value resistors fitted in parallel with the Series LDRs tend to bypass this filter: the improvement in HF performance is readily audible.
- Circuitry to vary total attenuator resistance.  
The ability to adjust the input-to-ground resistance ( $R_{TOT}$ ) to any value between five and about 25K is, without a shadow of doubt, THE LIGHTER NOTE's crowning glory.

## A high-end volume control using light-dependent resistors

Nothing allows you to appreciate better the benefits of a buffer-free design and the beguiling transparency of LDR attenuators than experimenting with  $R_{TOT}$  values. You can readily discover what is possible with this unique, variable-value LDR attenuator.

### Impedance matching

- I do not advocate buffers – instead, I advocate removing the need for them. A variable-value LDR attenuator does just that.

*Uriah Dailey*

As with any passive ‘pre-amplifier’, THE LIGHTER NOTE works best when the output impedance of the source is low, the input impedance of the amplifier is high, the connecting leads are short and their capacitance is kept to a minimum. The general principle for determining optimum  $R_{TOT}$  values is the 10-10 rule: it should be at least ten times the output impedance of the source and ten times less than the input impedance of the power amplifier. But it’s a rule of thumb, not a law. In practice, almost any source with a lowish output impedance driving an amplifier of around 100K input impedance will work well with low  $R_{TOT}$  values.

The ultimate in clarity is typically to be found when  $R_{TOT}$  is between five and 10K while that ‘tubey’ sound kicks in at around 22K. The recommended maximum is typically 15K – it’s there or thereabouts that you start to hear how low values of  $R_{TOT}$  offer better transparency.

You can go beyond 25K but LDRs do not match well at these higher values and are at their best below 22K (though balancing can help between 22 and 25K).

For amplifiers with 47K input impedance, try to keep  $R_{TOT}$  below 10K. The designer’s preferred setting for his amplifier, which has a 47K input impedance, is 6K. With slight circuit modifications,  $R_{TOT}$  can go as low as 3K and work successfully with amplifiers with 10K inputs.

If you are unsure about your source’s output impedance, note that most if not all digital-to-analog converters sold these days are under 200R.

### Further information

For technical support with this project, contact [diyldr@gmail.com](mailto:diyldr@gmail.com)

For purchases, visit [www.buildanamp.com](http://www.buildanamp.com)

For discussion on the LightSpeed circuit and on LDR attenuators in general, visit:

[www.diyaudio.com/forums/analog-line-level/80194-lightspeed-attenuator-new-passive-preamp.html](http://www.diyaudio.com/forums/analog-line-level/80194-lightspeed-attenuator-new-passive-preamp.html)

For a useful check on resistor color codes:

[http://samengstrom.com/nxl/8068/resistor\\_color\\_code\\_page.en.html](http://samengstrom.com/nxl/8068/resistor_color_code_page.en.html)

### This project involves mains power

**MAINS POWER CAN KILL!** Under no circumstances assemble, dis-assemble or construct mains-powered equipment unless you know what you are doing. Unless you are competent to observe safety rules and comply with local electricity regulations, seek the advice of qualified professionals. *Always* disconnect the power before attempting to work on a mains-powered device.

The author cannot be held responsible for end users performing tasks for which they are not competent.

## What THE LIGHTER NOTE kit includes

- |    |   |   |                                |
|----|---|---|--------------------------------|
| 1  | Printed Circuit Board                       | 3 | 200R Trimming Potentiometers   |
| 2  | 68R Resistors                               | 2 | 1K Trimming Potentiometers     |
| 2  | 240R Resistors                              | 2 | 5K Trimming Potentiometers     |
| 4  | 1K Resistors                                | 2 | 100K Trimming Potentiometers   |
| 10 | 22K Resistors                               | 1 | Dual-gang 1K Log Potentiometer |
| 2  | 249K Resistors                              | 1 | 5K Lin Potentiometer           |
| 2  | 1M Resistors                                | 4 | Terminal Blocks                |
| 2  | 10M Resistors                               | 2 | Integrated Circuit Sockets     |
| 2  | 20M Resistors                               |   |                                |
| 2  | 5-70 pF Mica Capacitors                     |   |                                |
| 10 | 0.47 $\mu$ F Film Capacitors                |   |                                |
| 6  | 1 $\mu$ F Tantalum Capacitors               |   |                                |
| 2  | 47 $\mu$ F Electrolytic Capacitors          |   |                                |
| 2  | 100 $\mu$ F Electrolytic Capacitors         |   |                                |
| 4  | 100 $\mu$ F Bipolar Electrolytic Capacitors |   |                                |
| 4  | 1000 $\mu$ F Electrolytic Capacitors        |   |                                |
| 6  | 1N4001 Diodes                               |   |                                |
| 2  | LEDs  |   |                                |
| 2  | LM317 Voltage Regulators                    |   |                                |
| 2  | LM334 Adjustable Current Sources            |   |                                |
| 2  | LME49710 Op Amps                            |   |                                |

### And what it doesn't . . .

To complete THE LIGHTER NOTE, you need to obtain a 12-0-12 volt transformer (5VA toroid recommended), a case, feet, knobs, signal connectors and sundries such as mains and signal wiring.

You will also need an IEC connector and insulating boot (or equivalent), a switch (optional) and a fuse-holder fitted with a correctly-rated fuse. (Values of 0.25 amps for 110-volt regions and 0.125 amps for 240-volt regions are recommended. Though power consumption is barely 0.5 watts, these values allow for power-on inrush currents.)

**Right: As with all electronic construction, take your time and work methodically. The use of solder flux makes for faster (and thus safer) soldering especially when mounting the LDRs – strongly recommended.**

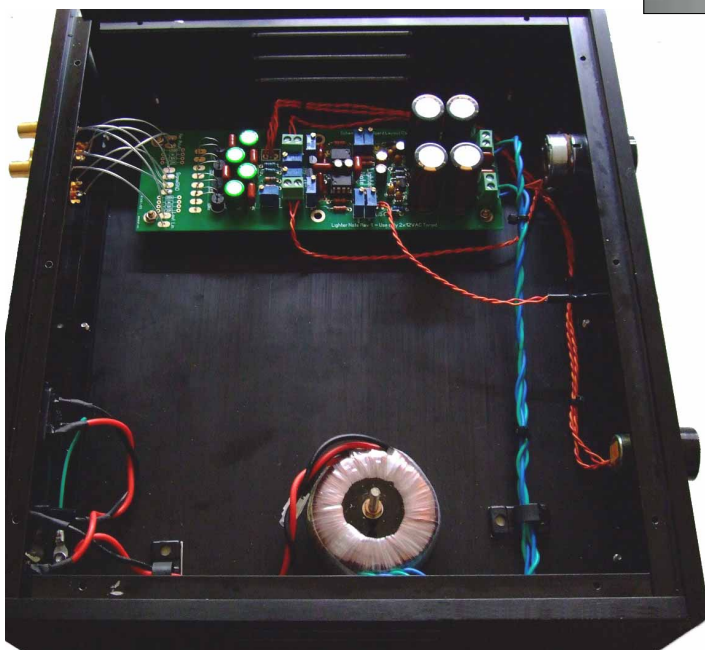
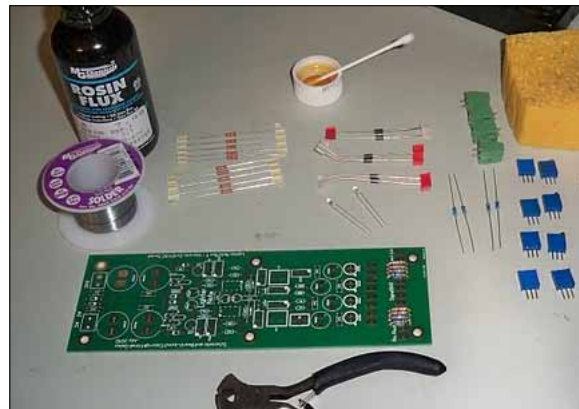

**Left: Constructor Bernie generously provided this picture of his completed kit. Note how he placed the transformer as far as possible from the PCB to prevent electromagnetic interference with the signal. (Distance and shielding are the only ways to do this.)**



## Assembling THE LIGHTER NOTE

THIS WARNING IS *NOT* one of those general ones that constructors like to ignore. If steps 13 to 19 of the procedure described below are not performed before powering up THE LIGHTER NOTE, you will almost certainly damage the LDRs and have to replace them. Do not start work and, above all, do not apply power to the board until you have carefully read these instructions.

Assembly is straightforward if you fit the components in the order given and check your work against the pictures. Constructors who follow the instructions very rarely damage the LDRs.

- These notes do not cover assembling the case, fitting RCA connectors and so forth. If you have any difficulties here, please contact Uriah Dailey at [diyldr@gmail.com](mailto:diyldr@gmail.com) for support.

**Step 1 – Low-profile components.** The polarities of the diodes (A) are shown on the right and of the LEDs in Step 2.

The high-value resistors mounted by the LDRs are packed separately – mount one each of 249K, 1M, 10M and 20M in each array. See Step 9.

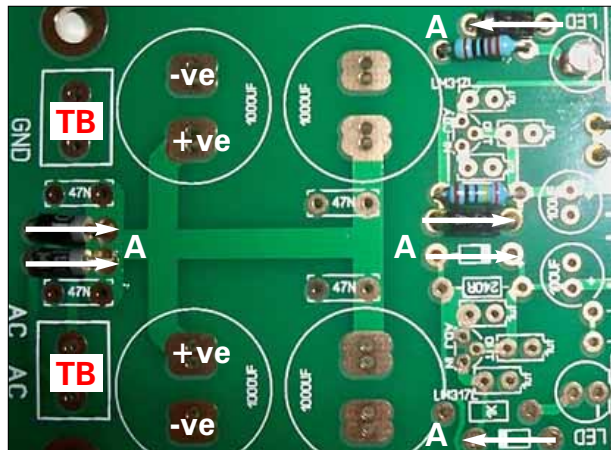

**Step 2 – Six tantalum capacitors.** These are polarised and all face the same direction: the holes for the longer, positive leads are sited towards the 1,000µF capacitors as shown.

LED polarities are also marked – see inset. The shorter, (cathode) leads go into the marked holes and the longer (anode) leads face the large capacitors.

The anodes of the diodes (circled in gray) are used as test points. See picture, Step 15.

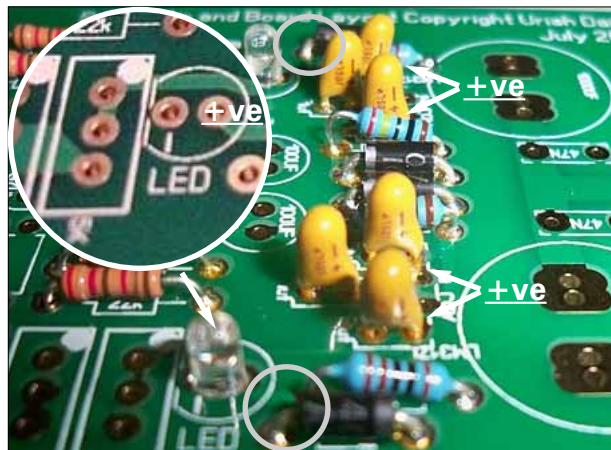

**Step 3 – Two mica capacitors.** Using pliers, carefully bend the leads to fit the holes as shown.

The circled marks to the left of the picture for orienting the op amps indicate pin 1, which is marked with a dimple on the chip.

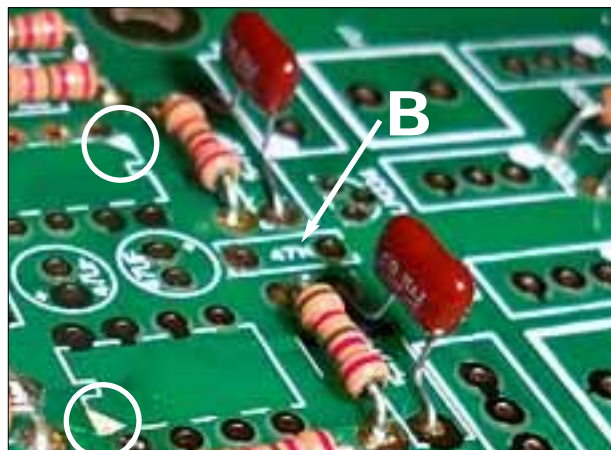

Step 4 – Two voltage regulators LM317L and two adjustable current sources LM334L as marked on the PCB. Do not push them right onto the board: leave some spare on the leads above the board to make it easy to clip on test leads;

Two 8-pin sockets and LME49710 op amps. Align the notch on the sockets and the dimple on the chip with the mark on the PCB as shown: note that the chips face in opposite directions.

Ten 470nF film capacitors. (Some of these – e.g. point B in Step 3 – are mistakenly labelled 47nF. All of them should of course read 470nF.)

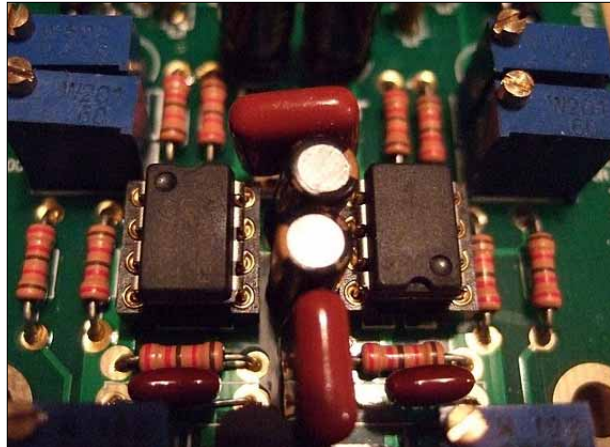

Step 5 – Nine trimmers. The values are also shown on the board. Their function is as follows:

- A 5K Series LDR voltage, coarse setting;
  - B 200R Series LDR voltage, fine setting;
  - C 1K Series LDRs, minimum resistance;
  - D 100K Series LDRs, maximum resistance;
  - E 200R Shunt LDR matching at min volume;
  - F 5K Shunt LDR voltage, coarse setting;
  - G 200R Shunt LDR voltage, fine setting;
  - H 1K Shunt LDRs, minimum resistance;
  - I 100K Shunt LDRs, maximum resistance;
- Points 1, 2, A & B connect to the volume control, C, D & E to the balance control.

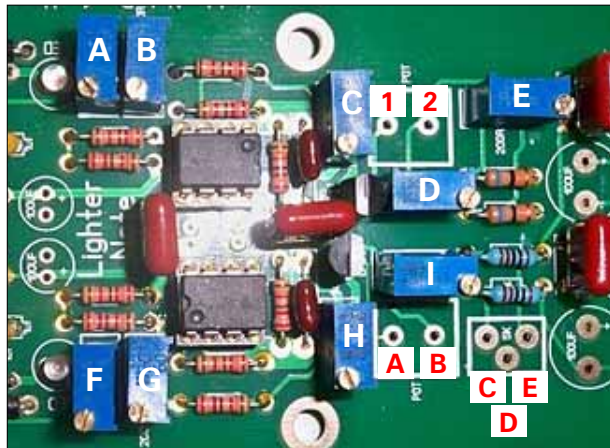

Step 6 – Four 100μF bi-polar electrolytic capacitors. These are sited next to the LDRs; note also four of the ten 470nF capacitors fitted in step 4.

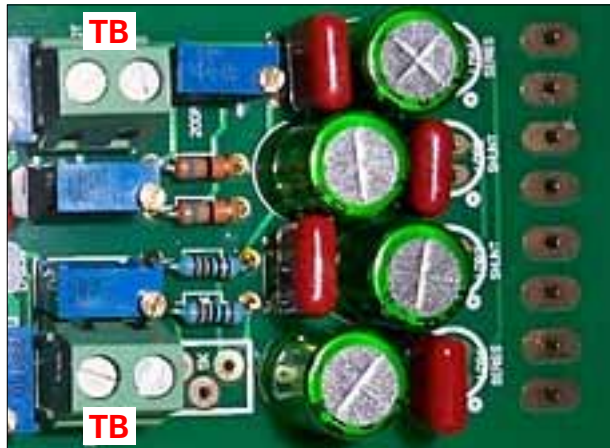

Step 7 – Two 100μF (A) and two 47μF (B) electrolytic capacitors. They are polarised – the holes for the longer, positive leads are marked on the board and the negative leads are marked on the component.

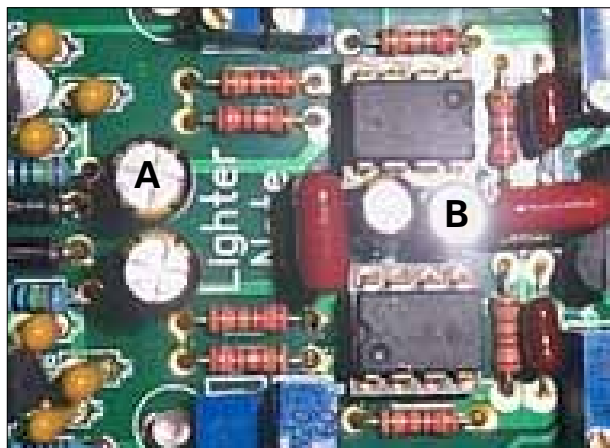



Step 8 – Four 1,000 $\mu$ F electrolytic capacitors. They are polarised – the longer, positive leads go into the holes at the centre of the board, the shorter, negative leads towards the edge of the board (see fig 1).

Four terminal blocks (marked TB in figs 1 and 6).



Step 9 – Four LDRs. Select the matched pair with the lower resistance for the Shunt LDRs.

The short leads connect to the LED, the long ones to the LDR. The white dot (arrowed) marks the LED's cathode: this must be inserted into the pad marked with a white dot (see below). If it isn't, please don't complain about dead LDRs!

The LDR leads are typically, as here, bent in the opposite direction for matching purposes. If so, this needs to be reversed.

Solder the devices with care: even if excess heat doesn't destroy them, it alters their values and they no longer match their partners. The LEDs (the shorter leads) are particularly fragile.

Use a hot iron and solder flux even with multicore solder. It is also worth using heatshunt pliers.

Don't solder the leads directly: put a good drop of solder on the tip of the iron and touch the tip on the pad onto which you are soldering the LDR.

When the solder wicks over to the pad, quickly roll the iron onto the leg of the LDR. As soon as the solder flows onto the leg, remove the iron even if the joint looks slightly messy. Blow on the device for a second or two to cool it.

Soldering should take three seconds at most. Wait a few moments before soldering the next leg.

As long as a joint conducts, that's it – do not re-apply the iron or try to remove the device from the board.

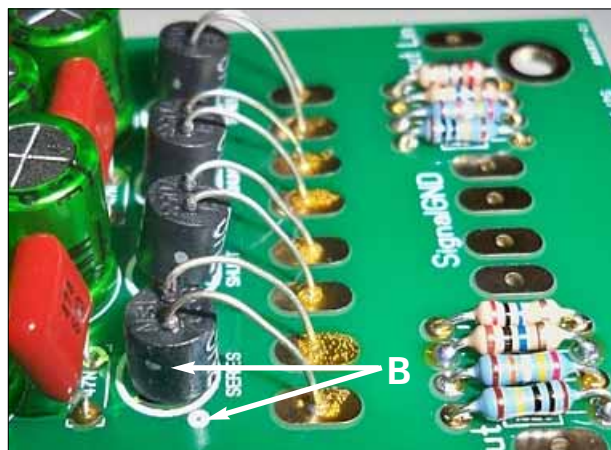

Step 10 – The dual, linear 1K pot. It controls volume and is mounted off-board. Lay the PCB in its enclosure and measure from the terminals to where the pot is to be mounted. Cut four lengths of wire to that length plus an inch or so (40 mm), strip 1/4 inch (6 mm) off both ends, solder one end to the pins on the pot and fit the others in the terminals. See picture, page 3 and Steps 5 and 6.

- The pot acts as  $R_{SET}$  for the LM334, i.e. it regulates how much current passes through the LEDs and thus how bright they are. These in turn change the resistance of the LDRs – the signal passes through the LDRs *not* the pot.

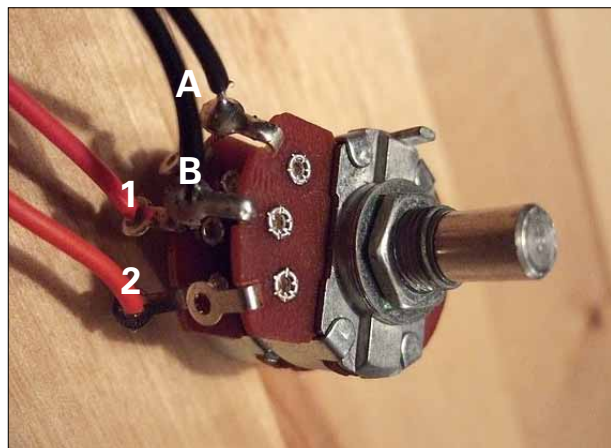

Step 11 – The 5K pot. It controls balance and is mounted off-board. Prepare three wires as above, solder one end of a wire to each pin on the pot. Solder the other end of the middle wire to the middle hole on the PCB and the other two to each of the other two holes. See picture, page 3 and Step 5.

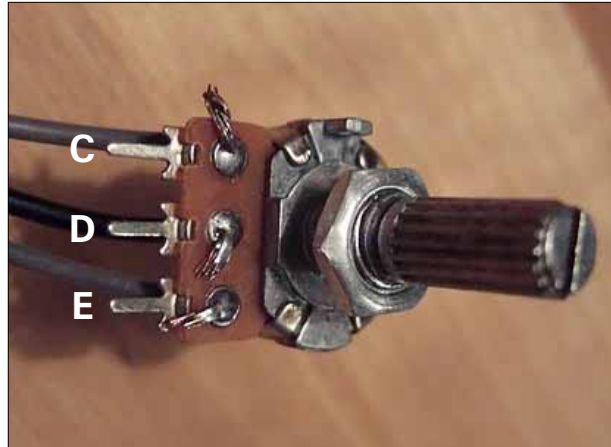

Step 12 – The mains transformer. This is mounted off-board. Because mains frequency and voltage differs from country to country and because they are expensive to ship, constructors should purchase a transformer locally.

The primary windings are connected in parallel in 115-volt regions and in series in 230-volt regions.

The secondaries are wired in series. The center-tap leads are connected to the terminal block labelled GND, the other two to the one labelled AC.

Connect GND to the mains Ground (Safety Earth), typically on an IEC connector.

- Do not tie power or earth grounds to the signal GND as they are usually connected in your source, your amplifier or in both. It serves no purpose but does inject noise.
- Locate the transformer and power supply wiring as far as possible from the signal leads – see picture, page 3. The high-value resistors by the LDRs significantly help sonics at high frequencies (especially the leading edge of drums) but they are susceptible to RFI.
- Good results have been obtained with AnTek's AN-0012, a 12-0-12, 5VA toroidal transformer.
- Do not apply power to THE LIGHTER NOTE for now – the instructions on page 8 explain how to protect the circuit during calibration.

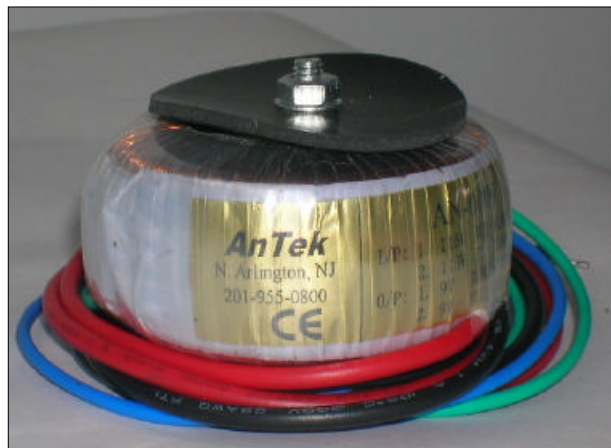
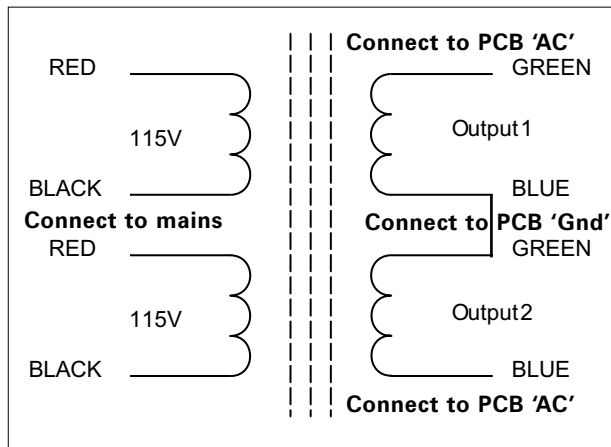

### Using other transformers

Even if a transformer's leads are not labelled, they are not hard to identify. The connections to the primary (mains) windings are almost invariably thinner than the secondary connections (one exception being the recommended AnTek where, unusually, the red, primary leads are the heavier).

To determine which secondary is which, set a DMM to read low resistance (typically the 200R scale), connect one lead to one of the four secondary wires and the other to the other three in turn. One should show a low resistance, typically between zero and five ohms. This is the other end of the first secondary winding. The other two should give no reading but should have a low resistance between them as they are the other secondary winding. Label the leads.

Twist one end of the first pair to one end of the second to form a 'center tap', set the DMM to read about 50 volts and apply mains voltage to the primary. (If you have a variable mains transformer, this is a good time to use it.) At mains potential, you should measure about 25 VAC between the two free leads and about 12 VAC between the center tap and each of the free leads.

If you don't, reverse the leads on one winding only and repeat the measurements.

## Calibrating THE LIGHTER NOTE

CALIBRATION IS key to getting the best results from THE LIGHTER NOTE and essential to protecting the Shunt LDRs. The procedure is very straightforward but do make sure you are familiar with these notes before starting, don't rush and proceed in the order described.

Components are identified in fig 5 unless otherwise stated. Steps 13 and 14 ensure that the board is correctly assembled, Steps 15 to 21 calibrate it. (Optional adjustments are described at the end.)

### Step 13 – Inspect your work

Examine the board, preferably with a magnifying glass, to ensure that polarised components are the right way round, no tracks are bridged with solder, no joints are badly soldered and so on.

This is easier if the board has been cleaned of solder flux. If you don't have a proprietary flux cleaner to hand, use an old toothbrush and nail polish remover then leave the board to dry overnight.

### Step 14 – Protect the Shunt LDRs

The Series LDRs are protected by 1K resistors but the Shunt LDRs have only 68R in series and can be destroyed by excess currents. (Higher values will not mute most amplifiers at minimum volume.)

The LM334 current sources must therefore not pass excessive current to the Shunt LDRs. *Before* applying power to THE LIGHTER NOTE in Step 15, set the 1K dual volume pot at its halfway point and adjust it only in accordance with these instructions until step 19 has been completed.

### Step 15 – Check the supply voltages

One of the LM317 regulators controls the voltage across the Shunt LEDs, the other that across the Series LEDs. They are adjusted using trimmers A and B (coarse and fine settings, Series) and F and G (ditto, Shunts). If the voltages are too low, the circuit doesn't work but, as factory supplied, the trimmers (and so the voltages) can be set anywhere. This step (a) ensures that the circuit functions and (b) sets LDR maximum resistances as low as possible (typically 6K).

For complete protection of the LDRs' internal LEDs during this step, first *disconnect the volume pot* then power up the board and check the LEDs by the LM317s are lit. (If not, verify your work.)

Set a DMM to read 20V DC. Connect one lead to the GNDGND terminal and the other to the anode of the diode at the outside of the board just by the target LM317 – see right and Step 2. Use the trimmers to set the voltage of the regulators to about 13 volts.

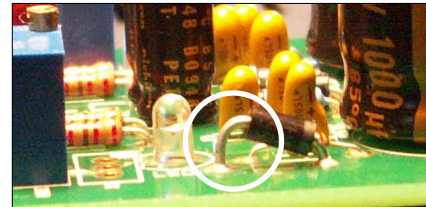

**Mount this diode as shown to provide a convenient test point.**

### Step 16 – Check the volume control wiring

Checking that the volume pot is still at the halfway point and reconnect it. Set the DMM to read 200R and connect it across one of the Shunt LDRs. Slowly turn the volume pot clockwise a few degrees: the LDR's resistance should increase. If instead it decreases, the pot is connected the wrong way round: move wires A & B to where 1 & 2 were and vice versa (Step 5).

### Step 17 – Match the Shunt LDRs

With the DMM still connected, *slowly* turn the volume pot down (CCW). Stop when the resistance falls to 100R, measure the other Shunt LDR and note both values. If either is below 40R, turn the pot up again to lift the LDR out of the sub-40 ohm 'danger zone' and repeat this step with the DMM connected to lower-value LDR.

Match the LDRs using trimmer E. As it turns, both LDRs change resistance. Switch the meter back and forth, measuring and trimming, measuring and trimming until the LDRs are within an ohm or two.

### Step 18 – Set Shunt LDR minimum resistance

To protect the LDRs, minimum Shunt LDR resistances must be at least 40 ohms. This step ensures that they are. Start by turning the volume pot slowly down until the first Shunt LDR measures 50R. Check



---

that the second is still close. (They might not go as low as 50R at this stage.) Proceed by slightly increasing the resistance of the Shunt LDRs with trimmer H then turning the volume pot down until it is at or approaching 40 ohms. Continue until both LDRs are equal to or slightly over 40 ohms when the pot is turned fully down. Do *not* go below 40R.

- Trimmer C has little effect here but can set a maximum volume – see *Controlling Dynamic Range*.

### Step 19 – Set maximum LDR resistance

Because low  $R_{TOT}$  values sound particularly transparent and detailed, LDRs are selected to match in the 5K to 20K range. Beyond that, they start to have wildly different resistance curves.

In practice, most constructors are happy with maximum LDR resistances of 22K or less. For hyper-transparent sound, set them as low as 6K; if you prefer that ‘tubey’ sound, go for 20K or over.

The maximum resistances are set using trimmer D for the Series LDRs and I for the Shunts. First, double-check that the resistance between the two outside pins of each trimmer is 100K or thereabouts. Next, turn the volume pot fully up and note the Shunt LDR resistances then fully down and note the Series LDR resistances. The aim is to make them the same: if, say, the Shunt LDRs are 10K at maximum, make the Series LDRs 10K at minimum. Adjust the trimmer while watching the readings.

### Step 20 – Test

Before connecting THE LIGHTER NOTE to a source and amplifier, verify that it is working correctly at low volume: with the power on, turn the volume pot right down and check that the shunt resistances are about 40R and the series resistances are several thousand ohms. Power off, connect a source and power amplifier and test, starting at low volumes.

### Step 21 – Calibrate balance

Matching LDRs involves measuring each device at four different amplitude levels and selecting accordingly. (Four levels yield as many matches as five or more – the procedure is optimum.) However, though accurate, it is not perfect: it is not possible to match devices at every level that might be used. Though few users encounter problems, there can be settings where the stereo image drifts slightly to one side. (It certainly doesn’t waver to and fro but it can be a little off center.)

The 5K pot is a conventional balance control: use it to center the image if necessary. The adjustment is one you may wish to make at your favorite listening level but not one you will be making constantly.

- That’s it. Congratulations on your successful build! Have fun . . .

### Controlling Dynamic Range

- A high-gain amplifier driving efficient speakers can go loud very quickly (i.e. after a small rotation of the pot) and may be quite loud even at minimum volume. This is normal with LDR attenuators: the shunt resistances cannot be less than 40 ohms for safety reasons but they need to be zero to mute a sensitive system.

One solution is to set maximum Shunt LDR resistances low and Series LDR resistances high as described in Steps 18 and 19. Another is to use trimmers A and B to adjust the voltage across the Shunt LEDs (Step 15): as it falls, maximum and minimum resistances both increase. If you start with, say, 100R to 6K and lower the voltage to make the maximum 15K, the minimum may be in the region of 5K. For an efficient system, this 5K to 15K ‘window’ may be just perfect. (Trimmers F and G adjust the voltage across the Series LDRs.)

- Tricks like this can stop kids cranking volume until it draws the attention of the authorities – the higher the minimum Series LDR resistance, the lower the maximum volume.